

Patents

Results of Search in US Patent Collection db for: TLX-Technologies

AN/TLX: 5 patents.

Hits 1 through 5 out of 5

- | PAT. NO. | Title |
|-----------------------------|---|
| 1 6,489,870 | T Solenoid with improved pull force |
| 2 6,392,516 | T Latching solenoid with improved pull force |
| 3 6,305,583 | T Valve for viscous fluid applicator |
| 4 6,199,823 | T Solenoid valve with an external sleeve armature |
| 5 6,198,369 | T Proportional actuator for proportional control devices |

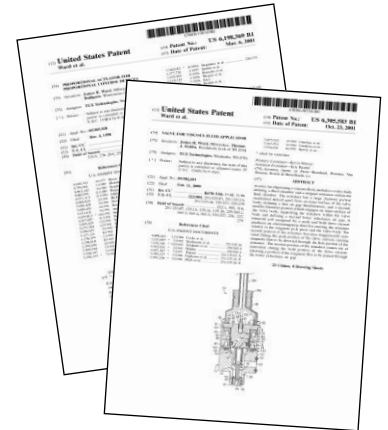

Patented TLX Technologies Solenoid Configurations

Proportional Solenoid Technology:

TLX's proportional control technology is a patented magnetic configuration that uses a stepped coil, (It# 70), and adds a saturation tip, (It# 74), formed on the end of the movable armature, (It# 66).

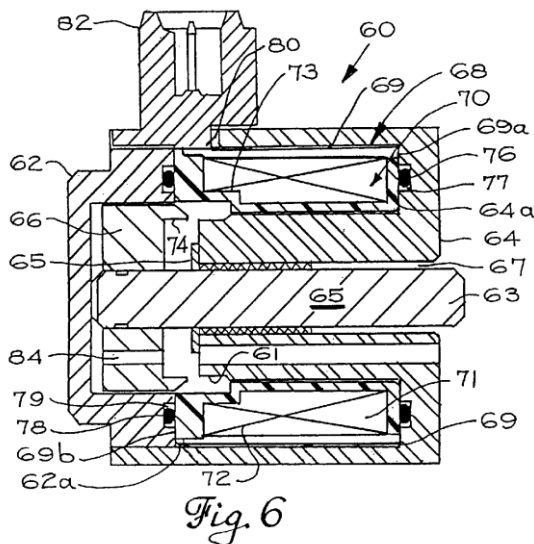

This is unlike standard solenoid configurations that use conical shapes or extensions up from the lower body in that TLX's stepped coil design provides clearance for the saturation tip, (which is extra magnetic material), on the moveable armature allowing the coaxial diameters the magnetic pole piece and, of the armature, to be increased for an actuator of a given size. These increased diameters, increase the lines of force "pulling" on the armature through stroke range thereby increasing the available force an additional 25% to 30% for a given actuator or valve package size.

Again, stating it somewhat differently, this patented magnetic configuration allows TLX to

fabricate actuators, solenoids or fluid valves with about 25% -30% more force in the same package size or conversely, we can reduce the package size by the same 25% - 30% and still maintain the same force levels.

On / Off Solenoid Technology:

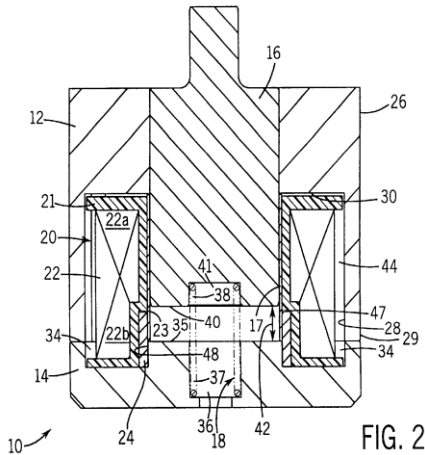

Another patented TLX electro-magnetic actuator configuration is the application of a "Shunt Ring" to the internal solenoid design. A solenoid of this configuration again utilizes a stepped coil design, (It# 22), but this time the available undercut is required to allow clearance for a ring, (It# 24), attached to the solenoid pole piece.

In this configuration the magnetic shunt member acts to bridge some of the long air gap between the pole face and the armature face and provides a low reluctance magnetic flux path between the pole member and the armature, increasing the attractive force between the armature and the pole member. The shunt member can be configured as a ring, as a washer, or as a combination of both a ring and a washer to gain the desired actuator or valve force profiles.

The net effect is to increase the "peak" starting pull in force of the solenoid vs. standard solenoid technology and, as with the proportional technology above, the "Shunt Ring" configuration allows TLX to package higher force solenoids in smaller package sizes

Digital Solenoid Technology:

Another product focuses is **Digital Technology**. Solenoids that encompass this technology can be single actuators or mated to valves offering extremely accurate and high-speed control of fluids or position.

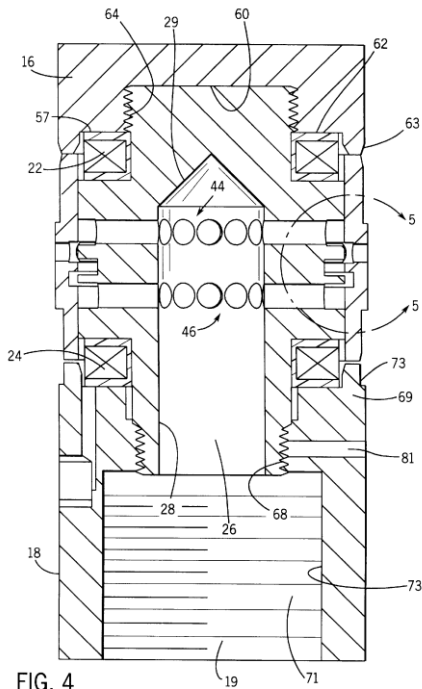

TLX has had great success adapting this technology to control the inflation rate of vehicle air bags & high-speed battery disconnects.

Basically, Digital solenoids utilize residual latching solenoid technology to allow the generation and decay of a magnetic field at very high speeds. This speed combined with patented control electronics produces solenoids and valves that have response times down to 200 microseconds.

In the shown example we actually reversed the valve design by having the spool external to the device. In this case the two coils, (It# 22 & 24), generate a field to attract the external spool, (the item shown in the listed detail #5), toward the pole tips, (It# 63 & 73), in a very rapid manner.

Because the forces generated by these digital devices are higher than standard solenoids it allows for accurate control of hi-pressure direct



injection fuel systems operating at 30,000 psi down to the lower 6,000 psi that is used in the TLX patented air bag control valve.

TLX non-digital Hi-Speed Solenoid Technology:

Adapting the knowledge gained from our work with digital solenoids has led to new designs of constant current solenoids and valves along with associated patents of the same. One of these patents is the unique flow path for the shown valve.

Within the valve this product replaced, turbulence and flow restriction were major issues for the customer. Our solution was to route the flow around the poppet to "straighten" the flow before exit from the valve.

Inlet of the fluid is at the port, (It#222), with the flow traveling up thru flow path, (#345), finally coming down the center of the poppet and being split by, (It#216), before being discharged thru the orifice within, (It# 226). The path, the flow pattern, and the armature configuration turned out to be unique in this application and when combined with the response time of the solenoid, gave our customer such an advantage that an exclusive license and manufacturing agreement was signed making TLX the only supplier of this product to the customer that has 80% of the worldwide market for this valve.

The listed technologies are only a few of TLX's patents. There are others, both issued and pending, that provide additional or modified technologies to address specific needs. We also routinely combine technologies to fit the force profile requirements of various applications and are looking to do this for several latching and proportional applications with several automotive and industrial customers.

