

Miniature Manual Reset Latching Solenoid

Description:

This latching solenoid example is manually actuated from the de-latched to the latched position. Once in the latched position, a permanent magnet field is used to hold the solenoid in the latched state. The solenoid is returned to the de-latched position by applying a short voltage or current pulse that cancels the permanent magnet field. Strokes and forces are flexible depending upon solenoid size.

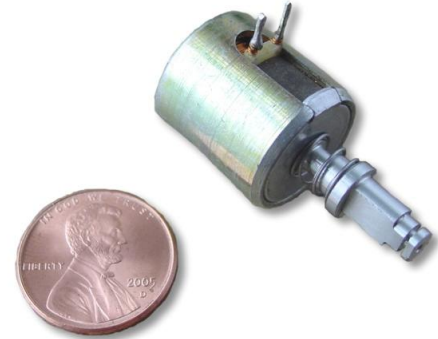

Features:

- Compact design
- High latching forces
- Fast response
- Low power consumption
- Can be designed for specific load holding capability
- Can be designed to configure with customer power requirements

Possible Applications:

- Air bag vents
- Battery disconnects
- Trunk release systems
- Vehicle door locks
- Battery operated locks
- Vending equipment
- Medical supply cabinets

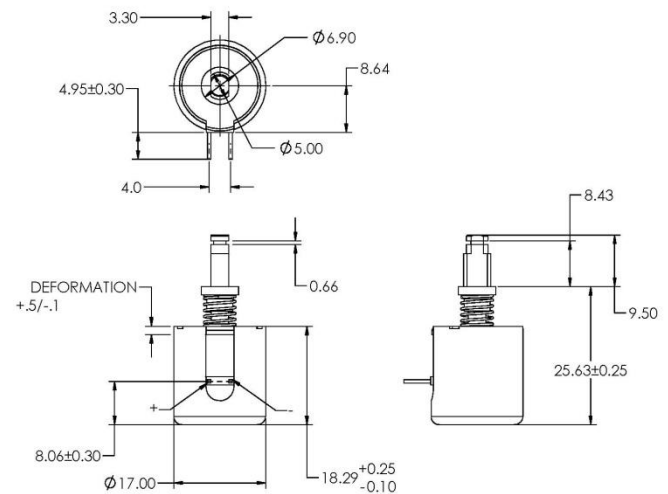

Example Specifications:

English (metric as applies)

Stroke (can be designed to specification)	.098 in (2.5 mm)
Holding Force	>6.29 lbs (>28 N)
Supply Voltage	6-16 Vdc
Response Time	>3 ms
Coil Resistance at 20°C	16.5 Ω ± 10%
Spring Load	1.124 lbs (5 N)
Current	.7 amps